

Passmaß	Abmaße
5 H7	+0,012 0

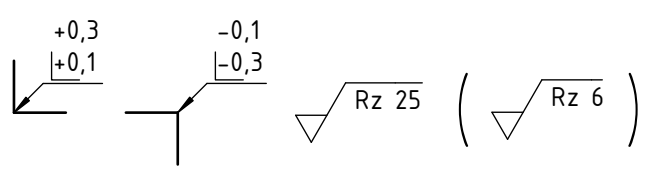
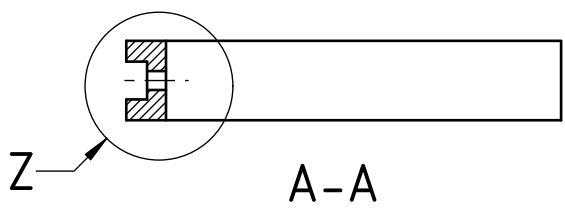
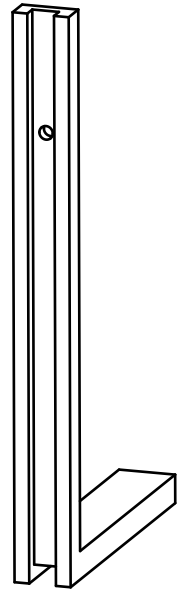
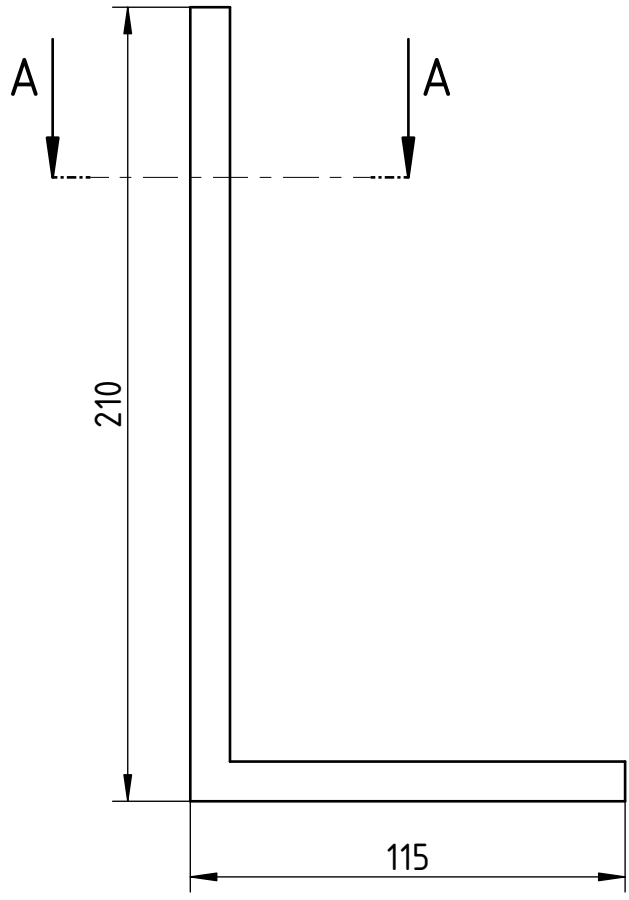
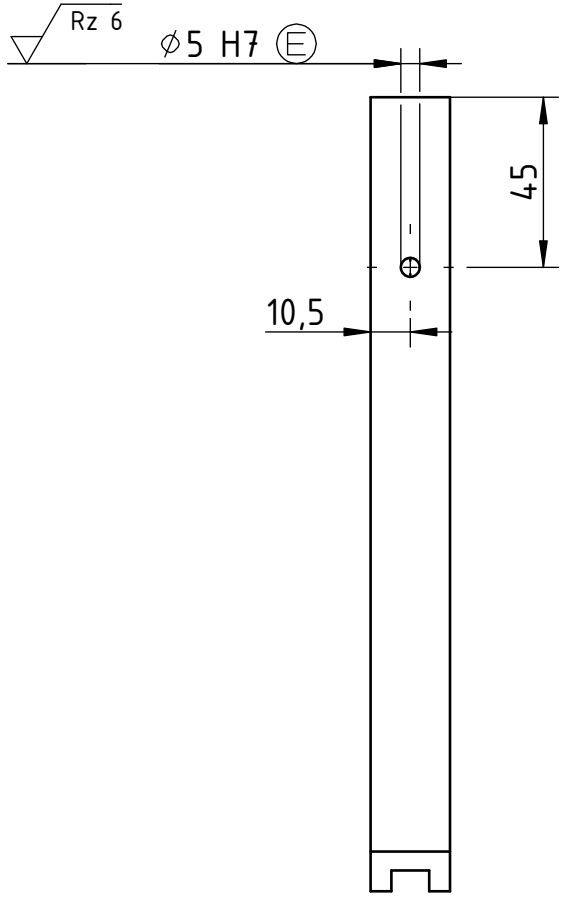
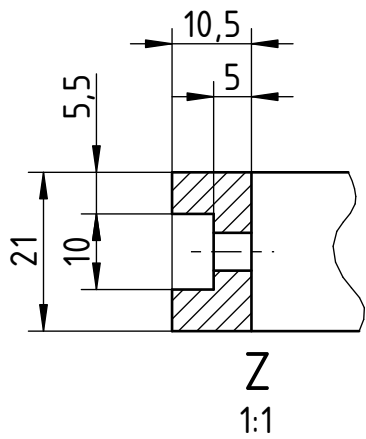

Allgemeintoleranzen nach DIN ISO 2768 - mK

Name	Matrikel	Benennung	Maßstab	Werkstoff
Creo Parametric Grundkurs	123456	011-123456-L-12	1:2 (1:1)	S235JR